

J-Series

Rigging manual (1.4 EN)

**WARNING!****References in the manual**

This refers to a potentially dangerous situation which may lead to personal injury.

CAUTION!

This refers to a potentially dangerous situation which may lead to damage to the equipment.

IMPORTANT!

This refers to a situation which may cause the equipment to malfunction.

Note:

Additional information and/or references.

Symbols on the equipment

Please refer to the information in the operating manual.

General Information

J-Series
Rigging manual

Version 1.4 EN, 10/2016, D2983.EN .01

Copyright © 2016 by d&b audiotechnik GmbH; all rights reserved.

Keep this manual with the product or in a safe place so that it is available for future reference.

When reselling this product, hand over this manual to the new customer.

If you supply d&b products, please draw the attention of your customers to this manual. Enclose the relevant manuals with the systems. If you require additional manuals for this purpose, you can order them from d&b.

d&b audiotechnik GmbH
Eugen-Adolff-Strasse 134, D-71522 Backnang, Germany
Telephone +49-7191-9669-0, Fax +49-7191-95 00 00
E-mail: docadmin@dbaudio.com, Internet: www.dbaudio.com

Contents

1. Safety precautions.....	4
1.1. Intended use.....	4
1.2. Load capacity/System safety.....	4
1.2.1. ArrayCalc simulation software / TI 385.....	4
1.3. Operational safety.....	5
2. J-Series rigging concept.....	6
2.1. Z5300 J Flying frame.....	6
2.1.1. System components overview.....	7
2.1.2. Z5300 J Flying frame center bar.....	8
2.1.3. Z5300 J Flying frame dimensions.....	9
2.1.4. Dimensions of the Mounting plate [1.3].....	9
2.1.5. Z5303 J Safety chain.....	10
Z5303 Specifications.....	10
2.2. Optional components.....	10
2.2.1. Z5305 J Hoist connector chain.....	10
Z5305 Specifications.....	10
2.2.2. E7441 Touring case 1 x Z5300 J Flying frame.....	10
3. Preparation.....	11
3.1. General preparations.....	11
3.2. Inspections.....	11
3.3. J-Series Locking pins.....	11
3.4. Splay link position at the Z5300 J Flying frame.....	12
3.5. Suspension of the Z5300 J Flying frame.....	13
3.5.1. J Load adapter.....	13
3.5.2. Single hoist set up.....	14
3.5.3. Dual hoist set up.....	14
3.6. Secondary safety.....	15
3.6.1. Secondary safety at the Z5300 J Flying frame.....	15
3.7. Horizontal aiming and securing of the array against rotation.....	16
4. J-Series arrays and assembly.....	17
4.1. Variant 1: J8/J12 Array.....	18
4.1.1. Preparations and order of assembly.....	18
4.1.2. Derigging.....	21
4.2. Variant 2: J-SUB and J8/J12 Arrays.....	22
4.2.1. Preparations and order of assembly.....	22
4.2.2. Derigging.....	26
4.3. Variant 3: J-SUB Array.....	26
4.4. Variant 4: J-Series ground stacks.....	26
4.4.1. Limitations for J-Series Ground stacks.....	26
4.4.2. Preparations.....	26
4.4.3. J8/J12 ground stack assembly.....	27
4.4.4. Ground stack with J-SUB and J8/J12.....	29
4.4.5. J-SUB stacks.....	29
5. Wind loads.....	30
6. Care and maintenance / Disposal.....	31
6.1. Transport / Storing.....	31
6.2. Visual and functional inspection.....	31
6.3. Disposal.....	31
EC Declaration of Conformity.....	32

1. Safety precautions

1.1. Intended use

The J-Series rigging components (Flying frame, Load adapter, Locking pins) must only be used in conjunction with the d&b J-Series loudspeakers J8, J12 and J-SUB as described in this manual.

Installation and set up should only be carried out by qualified and authorized personnel observing the valid national Rules of Prevention of Accident (RPA).

It is the responsibility of the person installing the assembly to ensure that the suspension/fixing points are suitable for the intended use.

1.2. Load capacity/System safety

The Z5300 J Flying frame is designed to suspend a total system weight of 1.5 t (3300 lb) WLL (Working Load Limit) according to BGV C1.

The rigging components allow arrays of up to 10 x J-TOP cabinets (J8/J12) or a total system weight of 665 kg (1466 lb) to be flown in any vertical splay angle configuration.

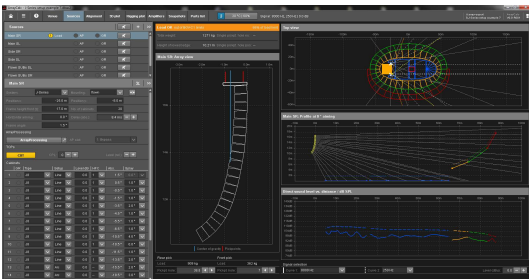

1.2.1. ArrayCalc simulation software / TI 385

For both safety and acoustic reasons, d&b line arrays must be designed using the d&b ArrayCalc simulation software. The software is available as a native stand-alone application for both Microsoft Windows and Mac OS X operating systems and can be downloaded at www.dbaudio.com.

Detailed information on how to use and operate ArrayCalc is provided by the Help system of the software. To access the Help system, press F1 or select the Help button () from the ArrayCalc toolbar. This will launch the HelpViewer which provides an overview of the program as well as a search function and direct access to the related topics.

In addition, ArrayCalc will provide you with typical array configurations within the permitted load limits and will help you get familiar with the mechanical load conditions and limitations.

Further information on line array design can be found in "TI 385 d&b Line array design, ArrayCalc". The TI is supplied with the software or can be downloaded from the d&b website at www.dbaudio.com.

We also recommend you to attend the regularly hosted d&b Line array training seminars. Further information regarding the d&b seminars and a seminar schedule can also be found on the d&b website at www.dbaudio.com.

1.3. Operational safety

During assembly pay attention to the possible risk of crushing hazard. Wear suitable protective clothing.

Observe the weight of the J-Series loudspeaker cabinets and the J Flying frame. Single person lift could cause injury – Lifting Hazard! Always use assistance when moving or lifting.



Observe all instructions given on the rigging components (Flying frame, Load adapter) and the loudspeaker cabinets.

When chain hoists are in operation ensure that there is nobody directly underneath or in the proximity of the load.

Under no circumstances climb on the array.

2. J-Series rigging concept

2.1. Z5300 J Flying frame

The Z5300 J-Flying frame is equipped and supplied with the following rigging components:

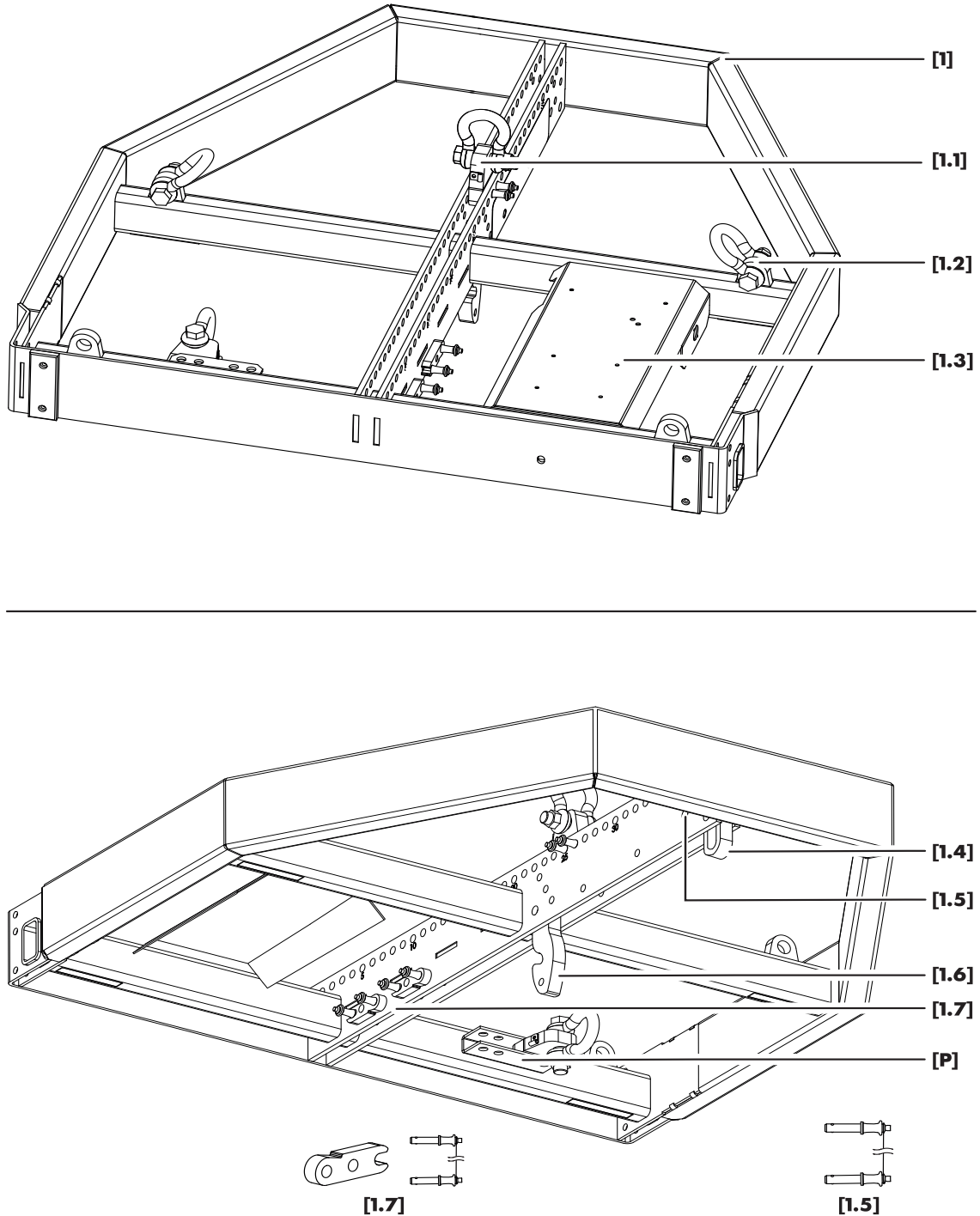

Fig. 1: Z5300 J Flying frame top and bottom view

2.1.1. System components overview

Pos.	Component	Description												
[1]	Z5300 J Flying frame	<p>The Z5300 J Flying frame is designed to support arrays consisting of the following J-Series loudspeakers:</p> <table border="1"> <thead> <tr> <th>Code</th> <th>Type</th> <th>Weight incl. rigging comp.</th> </tr> </thead> <tbody> <tr> <td>Z0650</td> <td>J8</td> <td>60 kg (132 lb)</td> </tr> <tr> <td>Z0651</td> <td>J12</td> <td>60 kg (132 lb)</td> </tr> <tr> <td>Z0660</td> <td>J-SUB</td> <td>106 kg (234 lb)</td> </tr> </tbody> </table> <p>The weight of the J Flying frame including all rigging components is 65 kg (143 lb)</p>	Code	Type	Weight incl. rigging comp.	Z0650	J8	60 kg (132 lb)	Z0651	J12	60 kg (132 lb)	Z0660	J-SUB	106 kg (234 lb)
Code	Type	Weight incl. rigging comp.												
Z0650	J8	60 kg (132 lb)												
Z0651	J12	60 kg (132 lb)												
Z0660	J-SUB	106 kg (234 lb)												
[1.1] [P]	J Load adapter Park position J Load adapter	The J Flying frame is supplied with two J Load adapters to allow single or dual hoist set up. Each J Load adapter is supplied with a pair of Locking pins 12 mm and a 3.25 t shackle. During transport the Load adapters should be stored at their park position [P]. (please refer to section 3.5 Suspension of the Z5300 J Flying frame on page 13)												
[1.2]	Safety point(s)	The J Flying frame is equipped with a total of four safety points to attach a secondary safety using the Z5303 J Safety chain and 3.25 t Shackles. (please refer to section 3.6 Secondary safety on page 15)												
[1.3]	Mounting plate	The J Flying frame is equipped with an additional mounting plate to accept industry standard inclinometers such as Rieker Instrument Company Inc. or SSE ProSight Inclinometer System.												
[1.4]	Cable pick	An O-Ring can be slid out by releasing the respective Locking pin for attaching a cable pick.												
[1.5]	Locking Pins 11 mm	<p>Two additional Locking pins 11 mm are supplied with the Flying frame and are located beside the cable pick. They are used to connect J-Series cabinets on top of the Flying Frame for the following set ups:</p> <ul style="list-style-type: none"> Mixed J-Series array with J-SUB cabinets at the top of the column. (Section. 4.2 Variant 2: J-SUB and J8/J12 Arrays from page 22) J-Series ground stack with the J Flying frame as ground support. (Section. 4.4 Variant 4: J-Series ground stacks from page 26) 												
[1.6]	Splay link (Frame)	<p>In conjunction with the Front links of the J-Series loudspeaker cabinets the Splay link of the frame is used to attach the first cabinet to the frame. By factory default the Splay link of the frame is fixed in J8/J12 position. To accept J-SUB cabinets the Splay link can be moved to J-SUB position. (please refer to section 3.4 Splay link position at the Z5300 J Flying frame on page 12).</p> <p>During transport the Splay link should be fold back to its park position and secured by the respective Locking pin.</p>												
[1.7]	Front link (Frame)	<p>Two additional Front links together with a pair of Locking pins 10 mm each are supplied with the J Flying frame. They are used to connect J-Series cabinets on top of the Flying Frame for the following set ups:</p> <ul style="list-style-type: none"> Mixed J-Series array with J-SUB cabinets at the top of the column. (Section. 4.2 Variant 2: J-SUB and J8/J12 Arrays from page 22) J-Series ground stack with the J Flying frame as ground support. (Section. 4.4 Variant 4: J-Series ground stacks from page 26) 												

2.1.2. Z5300 J Flying frame center bar

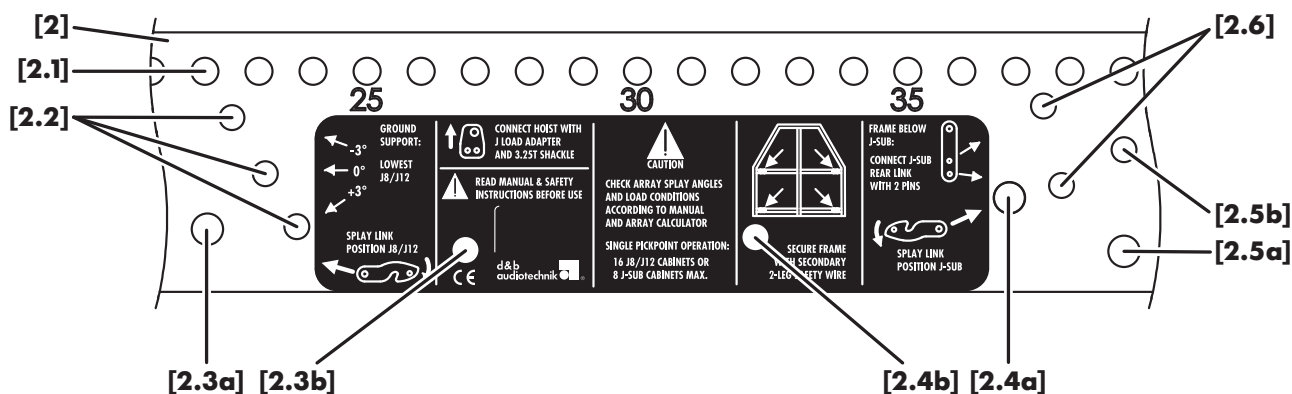

Fig. 2: Z5300 J Flying frame center bar with user instructions

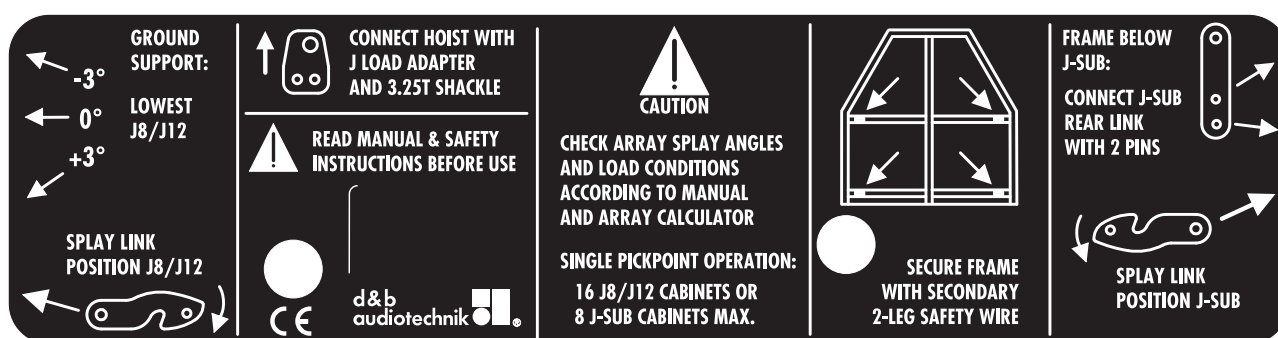

Fig. 3: Z5300 J Flying frame user instructions

Position	Description
[2]	Center bar of the Flying frame with user instructions.
[2.1]	Main hole grid at the top of the center bar with a total of 39 holes numbered with an increment of five. Using the J Load adapters the Flying frame can be suspended from one or two pick points. (please refer to the sections 3.5.2 Single hoist set up on page 14 and 3.5.3 Dual hoist set up on page 14)
[2.2]	Hole grid ground stack: when J8/J12 cabinets are attached to the top of the frame this hole grid indicates the possible settings of -3°, 0° or +3° for the Splay link of the lowest cabinet. The Splay link is to be connected to the frame using the additional Locking pins [1.5]. (refer to section 4.4 Variant 4: J-Series ground stacks from page 26)
[2.3a] [2.3b]	Fixing point for the frame's Splay link in J8/J12 position. (refer to section 3.4 Splay link position at the Z5300 J Flying frame on page 12). The additional hole [2.3b] is used to fix the Splay link in its park position using the respective Locking pin.
[2.4a] [2.4b]	Fixing point for the frame's Splay link in J-SUB position. (refer to section 3.4 Splay link position at the Z5300 J Flying frame on page 12). The additional hole [2.4b] is used to fix the Splay link in its park position using the respective Locking pin.
[2.5a] [2.5b]	Fixing point for the Cable pick (O-Ring). The additional hole [2.5b] is used to fix the O-Ring in its park position using the respective Locking pin.
[2.6]	Fitting the Flying frame below a J-SUB cabinet (Mixed J-Series array with J-SUB cabinets at the top of the column) these two holes are used to fix the Rear link of the respective J-SUB cabinet to the frame using the two additional Locking pins [1.5]. (refer to section 4.2 Variant 2: J-SUB and J8/J12 Arrays from page 22) These holes can also be used to park the two additional Locking pins [1.5] during transport.

2.1.3. Z5300 J Flying frame dimensions

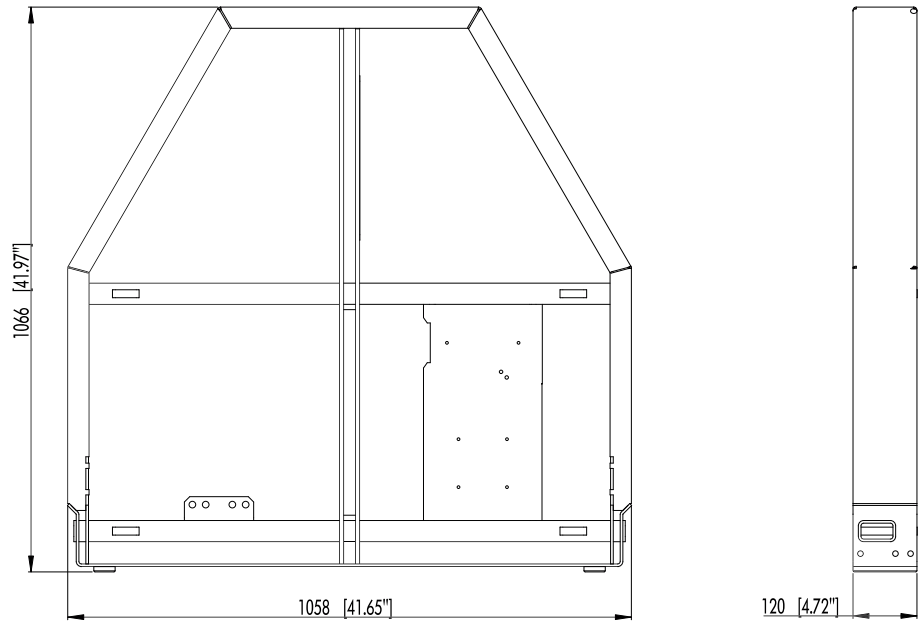

Fig. 4: Z5300 J Flying frame dimensions in mm [inch]

2.1.4. Dimensions of the Mounting plate [1.3]

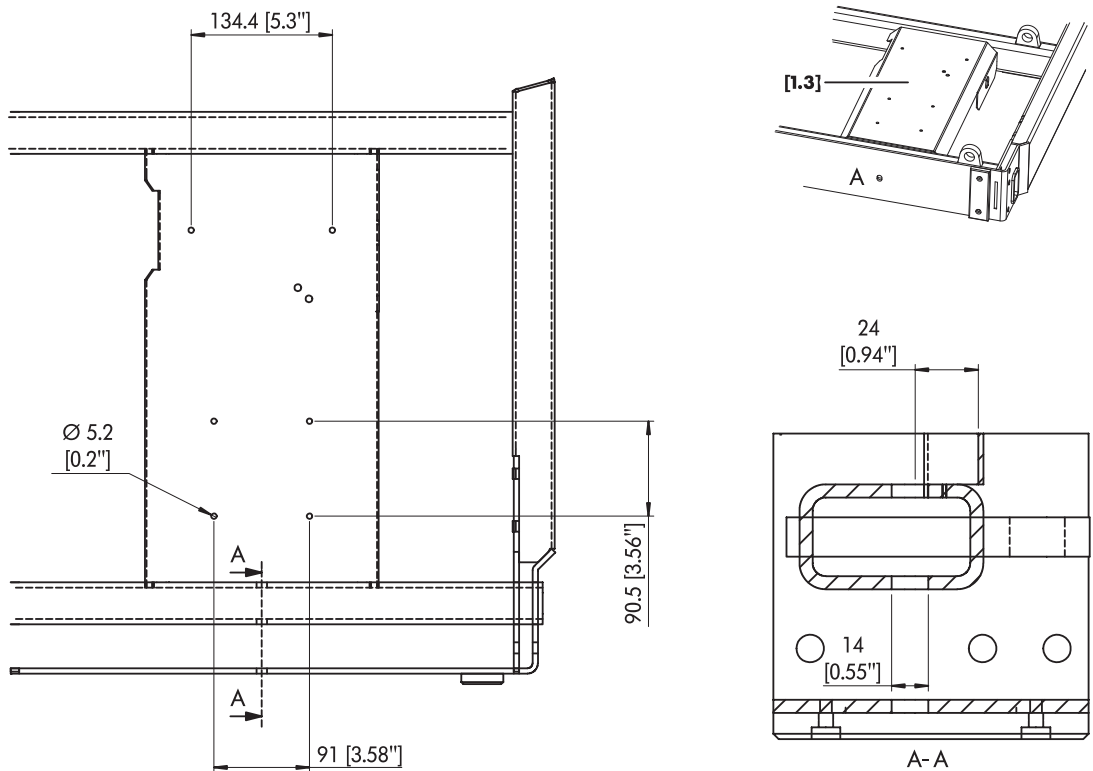

Fig. 5: Mounting plate dimensions in mm [inch]



Fig. 6: Z5303, J Safety chain

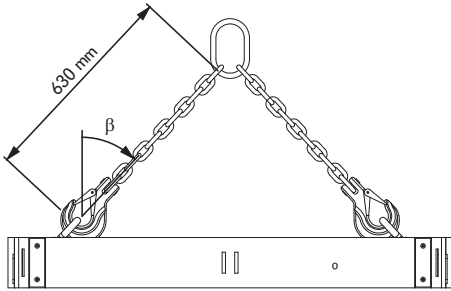

Fig. 7: Z5303, J Safety chain - Nominal length and sling β .

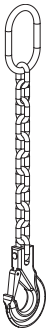

Fig. 8: Z5305 J Hoist connector chain

2.1.5. Z5303 J Safety chain

The Z5303 J Safety chain is supplied with the J Flying frame and is used as a secondary safety. (Please refer to section 3.6. Secondary safety on page 15)

Z5303 Specifications

Lifting chain.....	2-leg, 10 mm (DIN EN 818)
Nominal length incl. hooks for sling angle $\beta = 45^\circ$	630 mm
Maximum sling angle [β_{Max}].....	60°
Load rating.....	5.6 t (β : 0° - 45°)
.....	4 t (β : 46° - 60°)

2.2. Optional components

2.2.1. Z5305 J Hoist connector chain

The Z5305 J Hoist connector chain is used to connect the lifting motor(s) to the J Flying frame using the 3.25 t Shackles which is attached to the J Load adapter. Its length of 53 cm (21") allows enough space for the hang of most 2 t motor chain containers and avoids any influence to the vertical balance of the array when suspended from a single pick point.

Z5305 Specifications

Lifting chain.....	1-leg, 10 mm (DIN EN 818)
Nominal length incl. hook.....	535 mm
Load rating.....	4 t

2.2.2. E7441 Touring case 1 x Z5300 J Flying frame

The E7441 Touring case is designed to store one J Flying frame together with the Z5303 J Safety chain set and two Z5305 J Hoist connector chains. Its empty weight is 66 kg (146 lb). The overall weight is 145 kg (320 lb - including the Flying frame and all chain sets).

Using the E7441 Touring case the Flying frame can be assembled or picked up in different ways as described in:

- 4.1 Variant 1: J8/J12 Array
Fitting the J Flying frame on page 18.
- 4.2 Variant 2: J-SUB and J8/J12 Arrays
Preparation and assembly of the second Flying frame on page 24.

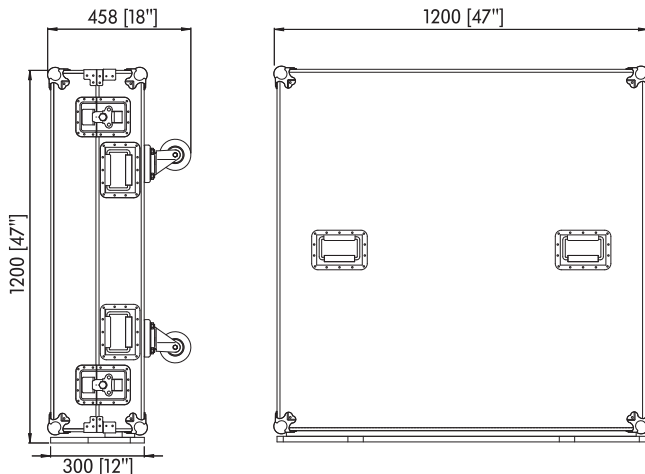

Fig. 9: E7441 Touring case for 1 x Z5300 J Flying frame, dimension in mm [inch]

3. Preparation

3.1. General preparations

Check the acoustical and mechanical set up with the ArrayCalc array calculator and prepare enough print outs for each array.

Using the plan, the riggers are able to set up the suspension points, the securing points and the chain hoists.

The working load limit of the chain hoists and their suspension points has to be high enough to carry the total system weight.

As during a dual hoist set up the motors might not always be synchronized each of the suspension points has to be able to carry the total system weight.

When on site first clear the working areas, check that the hoists are exactly in the specified position, the chains are not twisted and there is enough space to set up and lift the array.

3.2. Inspections

All system components must be inspected for faults before use. This also includes the loudspeaker and in particular the rigging parts of the cabinets.

Damaged components must be withdrawn from use immediately. Please pay attention to section 6. Care and maintenance / Disposal on page 31 of this manual.

3.3. J-Series Locking pins

The steel wire between the locking pins is not meant to suspend a cabinet or carry any load. The cabinet's weight must only be carried by the Front and Splay links in conjunction with front and rear rigging strands of the loudspeaker cabinets

Assembly

1. Pressing the button **[B]** releases the locking mechanism allowing insertion through the respective links or sockets.
2. Releasing the button after the pin is inserted and fixed in place the locking mechanism will be locked. A groove **[G]** (Fig. 10) in the bolt of the pin indicates that it is properly locked.



WARNING!



**LOCK PIN
SECURELY
BEFORE LIFTING**
ONLY UNLOCK FOR
DISASSEMBLY ON
GROUND

WARNING!

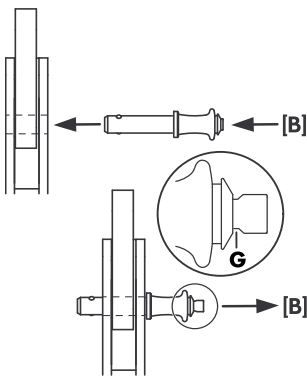

Fig. 10: J-Series Locking pins, Quicklock

Within the J-Series Rigging system the following types of Locking pins are used:

J-Series Loudspeaker (J8/12 and J-SUB)

- Locking pins 10 mm for the cabinet Front links. Linked in pairs with a steel wire and undetachably fixed to the cabinet.
- Locking pins 11 mm for the Splay (Rear) link at the central rear rigging strand. Linked in pairs with a steel wire and undetachably fixed to the cabinet.
- Locking pin 8 mm at the wheel board undetachably fixed to the wheel board with a steel wire.

J Load adapter/J Flying frame

- Locking pins 12 mm to attach the J Load adapter to the Flying frame. Linked in pairs with a steel wire and undetachably fixed to the Load adapter.
- Locking pin 11 mm for the Splay link and the cable pick of the frame to fix the respective component in its park position. Connected to the fixing bolt of the respective component with a rue ring cotter and a steel wire.
- Locking pins 10 mm for the two additional Front links at the Flying frame. Linked together in pairs with a steel wire.

3.4. Splay link position at the Z5300 J Flying frame



WARNING!

The fixing bolt of the frames Splay link is stressed by the full load of the array.

It is essential the bolt is fitted correctly and secured by the ring cotter when altering the position of the Splay link.

Ensure the ring cotter is properly locked.

Depending on the type of cabinet (J8/J12 or J-SUB) to be attached to the J Flying frame the position of the frames Splay link needs to be altered.

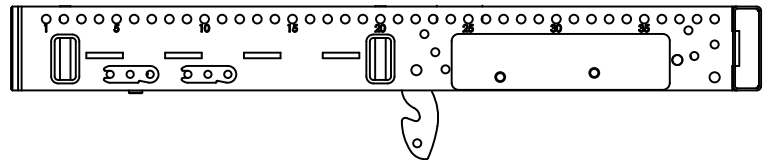

Fig. 11: Splay link frame – J8/J12 position

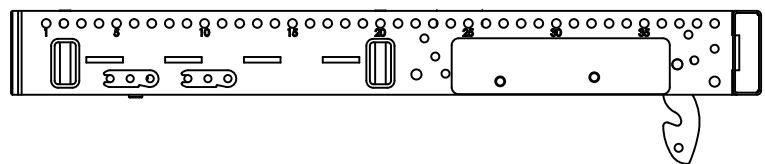

Fig. 12: Splay link frame – J-SUB position

To change the Splay link position proceed as follows:

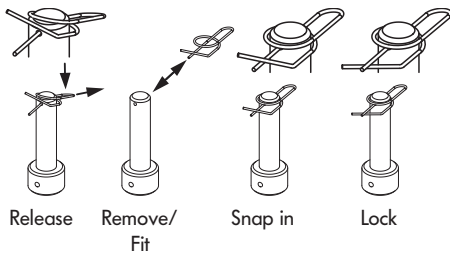
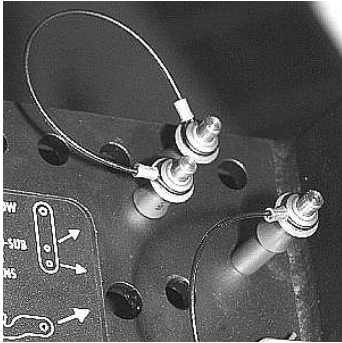

Fig. 13: Function of the ring cotter of the fixing bolt (schematic diagram)

Assembly

1. First alter the position of the additional Locking pins [1.5] as shown in Fig. 14 - Step 1.
2. Release and remove the Locking pin of the Splay link and fold out the Splay link.
3. Unlock and remove the ring cotter of the fixing bolt.
4. Remove the fixing bolt while holding the Splay link.
5. Move the Splay link to its new position and insert the fixing bolt.
6. Secure the fixing bolt with the ring cotter and ensure the ring cotter is properly locked.



Step 1



Step 2

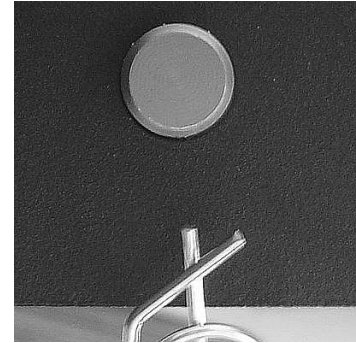

Step 3

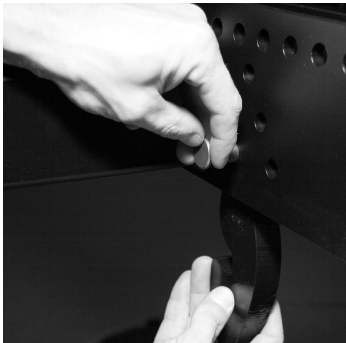

Step 4/5

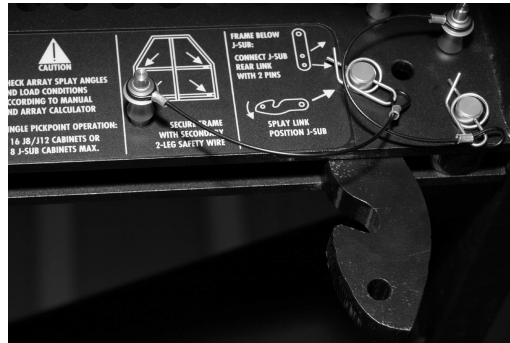

Step 6

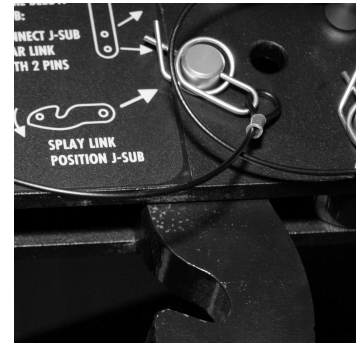

Fig. 14: Altering the Splay link position of the frame

3.5. Suspension of the Z5300 J Flying frame

3.5.1. J Load adapter

Before attaching the Load adapter check the 3.25 t. shackle is properly fitted to the Load adapter and secured against loosening.

The suspension of the J Flying frame is carried out using one or two J Load adapter fitted with a 3.25 t shackle, depending on the chosen type of suspension (Single or Dual hoist set up).

The Load adapter(s) are attached to the center bar of the Flying frame and fixed with the two Locking pins 12 mm of the Load adapter.

Ensure the Load adapter is properly attached to the center bar of the frame and both Locking pins are inserted and locked securely before lifting the array.



WARNING!

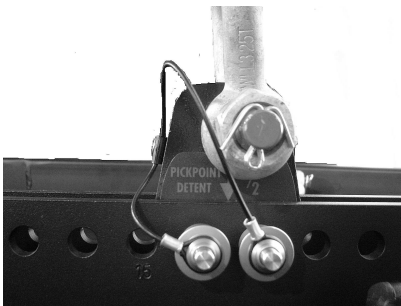

Fig. 15: J Load adapter

Single pickpt. hole no:	16
Single pickpt. hole pos:	40.9 cm

Fig. 16: ArrayCalc
Hole position for Single hoist set up

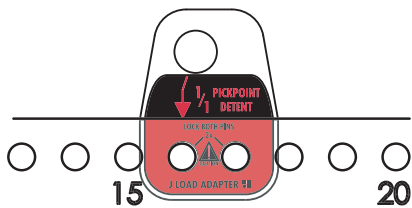

Fig. 17: Direction of the J Load adapter for full grid (1/1 Pickpoint Detent)
Shown: Hole 16

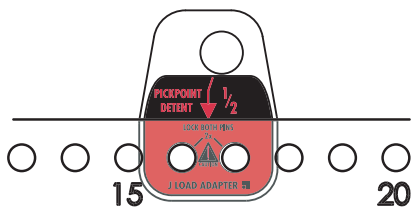

Fig. 18: Direction of the J Load adapter for half grid (1/2 Pickpoint Detent)
Shown: Hole 16,5

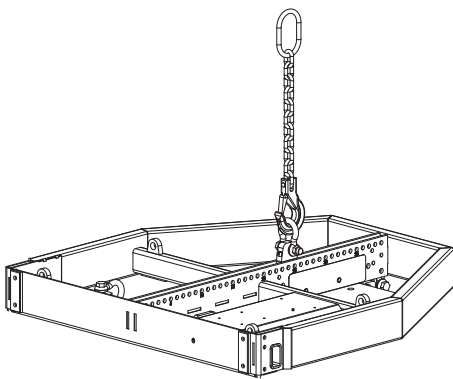

Fig. 19: Single hoist set up

Rear pick	Front pick
Load: 230 kg	Load: 197 kg
Pickpt. hole: 38.5	Pickpt. hole: 1

Fig. 20: ArrayCalc
Hole positions for Dual hoist set up

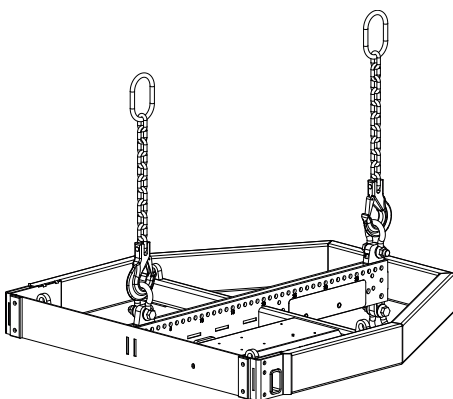

Fig. 21: Dual hoist set up

3.5.2. Single hoist set up

When suspending the array from a single pick point (Single Pick point Operation) the following limits apply:

Maximum system weight of 1025 kg (2260 lb) or accordingly:

- Max. 16 x J-TOP cabinets (J8/J12)
- Max. 8 x J-SUB cabinets

In "Single Pickpoint Operation" the position of the J Load adapter defines the vertical aiming of the whole array.

The corresponding hole position is calculated using ArrayCalc (Fig. 16) and can be set in a 1/2-hole resolution at the top of the center bar of the J Flying frame.

The J Load adapter allows a full grid (1/1 Pickpoint Detent) or a half grid (1/2 Pickpoint Detent) setting depending on its direction of attachment (Fig. 17/18).

The frame's hole index marked on one side of the center bar of the frame is the reference for the direction of the Load adapter.

Attaching the Load adapter

1. Choose the appropriate hole position in the J Flying frame center bar according to the ArrayCalc simulation and attach the J Load adapter correspondingly.
If ArrayCalc displays a half numbered hole setting (half grid) turn the J Load adapter correspondingly (refer to Fig. 18)
2. Connect the Z5305 J Hoist connector chain to the 3.25 t Shackle of the J Load adapter.

3.5.3. Dual hoist set up

When suspending the array from two pick points the following limits apply:

Maximum system weight of 1.5 t (3300 lb) or accordingly:

- Max. 24 x J-TOP cabinets (J8/J12)
- Max. 14 x J-SUB cabinets

With Dual hoist setup the vertical aiming of the array will be set by trimming the hoist motors after the array is fully assembled and lifted to its operating position. The corresponding hole positions of the Load adapters is calculated using ArrayCalc - Fig. 20.

Attaching the Load adapter

1. Choose the appropriate hole positions for the Front and Rearpick in the J Flying frame center bar according to the ArrayCalc simulation and attach the J Load adapters correspondingly (Direction: Full grid 1/1 Pickpoint Detent).
2. Connect one Z5305 J Hoist connector chain each to the 3.25 t shackle of the respective J Load adapter.



WARNING!

3.6. Secondary safety

The secondary safety suspension must be independent of the primary suspension points and capable of carrying the total system weight.

The additional safety device must be mounted in a way that the array is caught by the safety device without any drop and swing in the event that the primary suspension fails.

3.6.1. Secondary safety at the Z5300 J Flying frame

The Z5300 J Flying frame is equipped with four safety points [1.2]. Two are located at the front bar and two at the cross bar of the frame. The latter being the default suspension for the secondary safety are fitted with two 3.25 t shackles.

We recommend the use of the Z5303 J Safety chain set which is supplied with the J Flying frame.

Assembly

1. Before attaching the safety device ensure the two 3.25 t shackles are properly fitted to the frame and secured against loosening with a locked ring cotter - Fig. 22.
2. When attaching the Safety chain set ensure the chains are not twisted and the hooks [H] are in the right direction as shown in in the graphic below - Fig. 23.



Fig. 22: Ring cotter to secure the 3.25 t shackle [S].

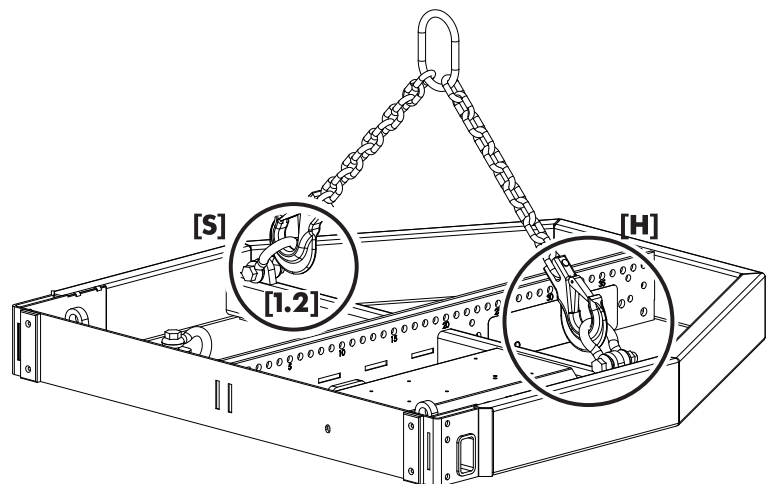

Fig. 23: Secondary safety at the Flying frame



WARNING!

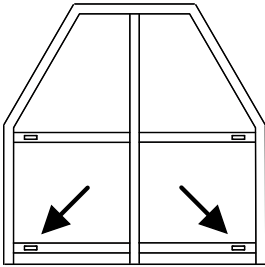

Fig. 24: Safety points of the frame for horizontal aiming and protection against rotation and swing

3.7. Horizontal aiming and securing of the array against rotation

If the system is used in an open air environment the influence of wind has to be taken into account. The protection against rotation and swing has to withstand higher forces. Refer to section 5. Wind loads on page 30.

After the array has been lifted to its operating position the horizontal aiming has to be set and the array should be secured against rotation and swing.

The protection should be applied to the remaining safety points of the Flying frame - Fig. 24.

4. J-Series arrays and assembly

J-Series loudspeakers and J Flying frames may be assembled in the following ways.



Variant 1: J8/J12 Array
(Refer to section 4.1 starting from page 18)



Variant 2: J-SUB and J8/J12 Array
(Refer to section 4.2 starting from page 22)



Alternative variant 3: J-SUB Array
(Refer to section 4.3 starting from page 26)



Variant 4: J Ground stacks
(Refer to section 4.4 starting from page 26)



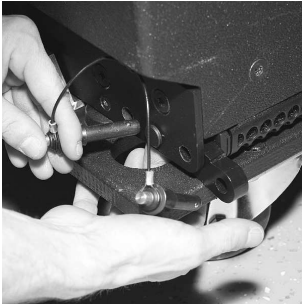

a)

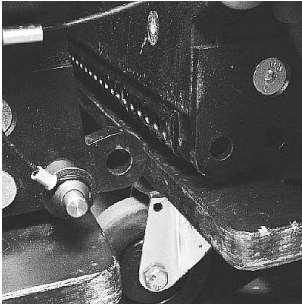

b)

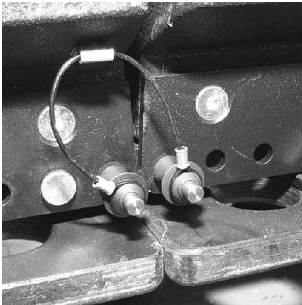

c)

Fig. 25: Front links assembly



Fig. 26: J Flying frame within the E7441 Touring case

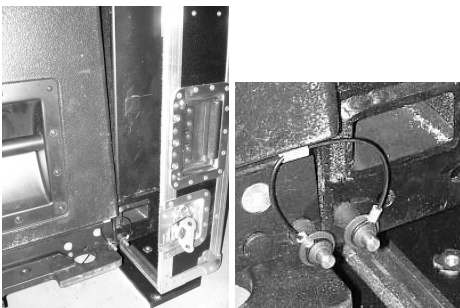

a)

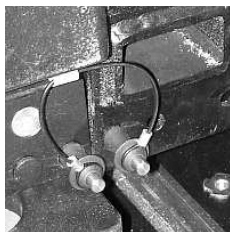

b)

Fig. 27: J Flying frame assembly

4.1. Variant 1: J8/J12 Array

4.1.1. Preparations and order of assembly

The array can be assembled on the ground completely without the need of lifting the cabinets by hand. On their wheel boards the cabinets can be easily moved into position and joined together.

1. Prepare the flying cables and link cables according to the number of amplifier channels and cabinets used.
2. Arrange the cabinets in the right order and direction to be joined together as follows:

Joining the cabinets together (Fig. 25a – c)

3. With one person on each side of the cabinets first release and remove both Locking pins of the cabinet's Front links. The links can be accessed through the holes in the wheel boards and slid out to their stop position. (Fig. 25a)
4. Insert one pin to the respective socket to fix the Front links in place. (Fig. 25b)
5. Insert the Front links into the front rigging strands of the next cabinet and lock them with the second pin (Fig. 25b).

Repeat steps 3 to 5 in the same manner until all cabinets are joined together.

Note: For an easy attachment of the Flying frame it is advisable to connect at least two cabinets before fitting the Flying frame to the top cabinet as described below.

Fitting the J Flying frame (Fig. 26, Fig. 27a/b; Fig. 28)

The J Flying frame can be fitted to the top cabinets Front links using the E7441 Touring case. The Touring case enables the J Flying frame to be positioned in the exact vertical level of the cabinet Front links. To do so the Flying frame must be positioned with the hole grid of the center bar facing down and the front of the frame facing towards the wooden baseboard of the Touring case.

6. Prepare the Front links of the top cabinet in the same manner as done in step 3 and 4.
7. With one person on each side open the case and tilt the J Flying frame upright using the wooden baseboard of the Touring case and position it towards the top cabinet of the column.
8. Release the velcro strips of the Touring case which hold the Flying frame in place.
9. Move the cabinets towards the frame until the Front links of the first cabinet are completely inserted into the front tracks of the Flying frame. (Fig. 27a)
10. Insert and lock the Locking pins of the cabinet to the respective holes of the Flying frame. (Fig. 27b)



Fig. 28: Splay link of the frame connected to the first cabinet



Fig. 29: Preset the splay angles



Fig. 30: J Load adapter fitted and hoist connected

11. Release and remove both Locking pins of the central rigging strand at the rear of the top cabinet.
12. Release and remove the Locking pin of the frame's Splay link and fold it out.
13. Attach the Splay link to the central rigging strand at the rear of the top cabinet and lock it with the two pins of the cabinet (0° and 4° hole - Fig. 28) and remove the Touring case.

Rig the cabling

14. Connect the flying cables and link cables according to the number of amplifier channels and cabinets used.

Preset the splay angles (0° ... 6° settings; Fig. 29)

Note: The maximum splay angle of 7° is not being preset. For the 7° position both Locking pins will be fixed later during the lifting procedure described from step 21 when the full splay is reached.

15. Preset the splay angle of each cabinet according to your ArrayCalc simulation by inserting one pin to the respective hole of the central rigging strand.
16. Release the other pin which is holding the Splay link in place and put it aside. This pin is used to secure the Splay link when fixing the splay angles in a later step.
17. Swing off the Splay link of the cabinet to the central rigging strand of the next cabinet.

Attach the pick point

18. Depending on the type of suspension (single or dual hoist set up as described in section 3.5 on page 13) attach the J Load adapter to the center bar of the J Flying frame and connect the hoist. (Fig. 30)

Attach the secondary safety device

19. At this point of the set up we recommend to attach the secondary safety device using the Z5303 J Safety chain set as described in section 3.6 Secondary safety on page 15.

Checking the actual set up

20. Before continuing with the set up it is recommended to check the actual status of the assembly as follows:

- Check the assembly of the Flying frame to the first cabinet (Front and Splay links) and ensure all Locking pins are properly locked.
- Check the attachment of the Load adapter(s) to the Flying frame and ensure all Locking pins are properly locked.
- Check the assembly of the secondary safety device at the Flying frame. (refer to section 3.6 on page 15)
- Check the assembly of all Front links to both sides of the cabinets and ensure all Locking pins are properly locked.
- Check the preset splay angles.



a)

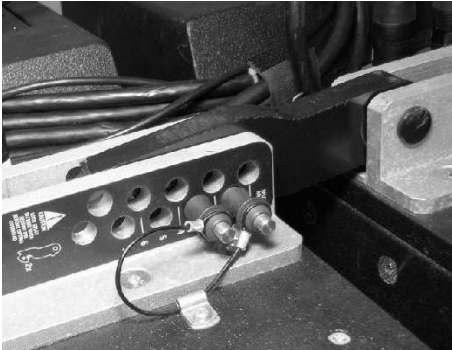

b)

Fig. 31: Fixing the splay angles

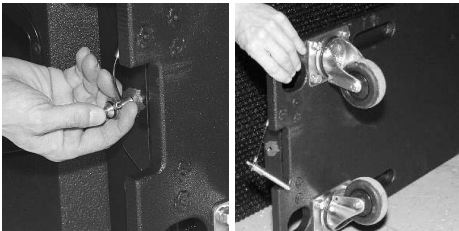

a)

b)

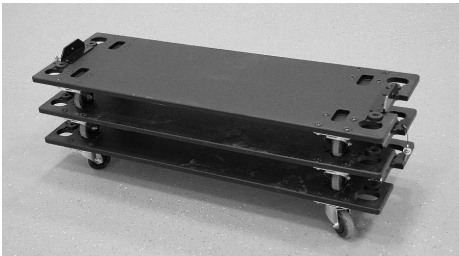

c)

Fig. 32: Removing the wheel boards

Fix the splay angles

21. Lift the Flying frame using the hoist until the first Splay link has hooked over the preset Locking pin. (Fig. 31a/b)
22. Lower the Flying frame until the second securing Locking pin can be inserted into the hole below the preset pin. (Fig. 31b)
23. Repeat this procedure of lifting and lowering cabinet by cabinet until all splay angles are fixed and the Splay links are secured with the Locking pins.

Alternatively this procedure can be applied to a group of cabinets in one step. In this case lift the Flying frame using the hoist until all Splay links of the group have hooked over their preset Locking pins (0° ... 6°). Lower the Flying frame and insert the remaining securing Locking pins until all splay angles are fixed and all Splay links are secured.

Remove the wheel boards (Fig. 32a-c)

The wheel boards have a fixed pin at one side and a removable pin to the other side and they can be fitted to the cabinet either way around. Using the recessed holes on top the wheel boards can easily be stacked and stored aside.

24. Rise the array until the wheel board of the top cabinet is in an accessible height.
25. With one person on each side of the cabinets first release the pin while holding the wheel board.
26. Slightly fold off the board and move it towards the other side to release the fixed pin.
27. Take off the wheel board.
28. Remove all accessible boards in the same manner.
29. Lift the array to get access to the remaining wheel boards and remove them in the same manner.

Check the whole set up

30. Check the assembly of the Splay/Rear links at the rear of the cabinets and ensure all Splay links are secured with two pins..
31. Check the wiring.
If the amplifiers are already wired and powered on, using their System check function or channel mute switches and a test signal the correct function and routing of all channels and cabinets can be verified.

Hoisting and securing the array

When all the mechanical adjustments, system checks and safety checks have been made the array can be hoisted up to its operating position.

When hoisting the array, ensure that the loudspeaker cables do not get caught anywhere. The cables can be strapped together with the motor cable to form a loom while the system is hoisted.

The chain hoist motors must raise the system slowly and evenly so that it does not swing or move from side to side during hoisting.

When the array is in its final operating position the secondary safety must be applied. A detailed description is given in 3.6 Secondary safety on page 15.

4.1.2. Derigging

The same safety instructions as for the set up apply and the following order is recommended:

1. Lower the array and stop before the lowest cabinet hits the ground.
2. Attach the wheel boards beginning with the lowest cabinet.
3. Continue to lower the array and carefully tip the lowest wheel board onto the ground.
4. Stop lowering the array at this point.



Continuing lowering the array at this point could lead to the potential risk to tip over the array towards the front before - depending on the type of ground (arena floor/free field) - the array could roll towards the back in a sudden.

This will cause a potentially dangerous situation which may lead to personal injury.

In particular make sure that during lowering the array no person is underneath or within the vicinity of the array.

Before continuing lowering the array with one person to each side of the array give support to the side handles of the lowest cabinet. While lowering the array give direction towards the back of the array to ensure the array will be lowered straight down and safely rolled to the back. It is advisable all persons involved in lowering the array are close by to give instructions if necessary.

5. Continue to lower the array and with one person on each side of the cabinets attach the remaining wheel boards.
6. When all wheel boards are attached the array can be fully dropped onto the ground.
7. Remove the cabling.
8. Remove the lower Locking pins which were used to secure the Splay links.
9. Lift the Flying frame until the full curving of the array is reached and the hooks of the Splay links are released.
10. Flip back the Splay links to their park position and fix them with the Locking pin.
11. Lower the Flying frame again until all cabinets stand on their wheel boards.
12. Remove the Flying frame and store all items (Splay link / Load adapter) back into their park positions.
13. Separate the cabinets and store back the Front links into their park position.

4.2. Variant 2: J-SUB and J8/J12 Arrays

Unlike an array of J-TOP cabinets only with mixed configurations the cabinets are lifted and attached to the array one by one.

For flown arrays of J-SUB and J8/J12 cabinets two J Flying frames must be used.

CAUTION!

If the array contains J-SUB cabinets these must always be positioned at the top of the column.

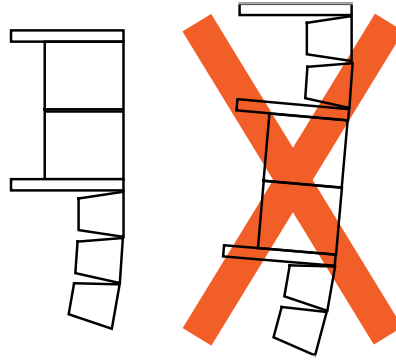

4.2.1. Preparations and order of assembly

1. Prepare the flying cables and link cables according to the number of amplifier channels and cabinets used.
2. Decide where to fix the cable pick depending on single or dual hoist suspension.

Preparation and suspension of the first frame

3. The Splay link of the first frame must be fitted in J-SUB position. Check the position of the Splay link and alter the position if necessary as described in section 3.4 Splay link position at the Z5300 J Flying frame on page 12.
4. Depending on the chosen type of suspension (single or dual hoist set up as described in section 3.5 Suspension of the Z5300 J Flying frame on page 13) attach the J Load adapter to the center bar of the J Flying frame.
5. Connect the hoist(s) to the Load adapter(s).

Attaching the secondary safety device

6. At this point of the set up we recommend to attach the secondary safety device using the Z5303 J Safety chain set as described in section 3.6 Secondary safety on page 15.

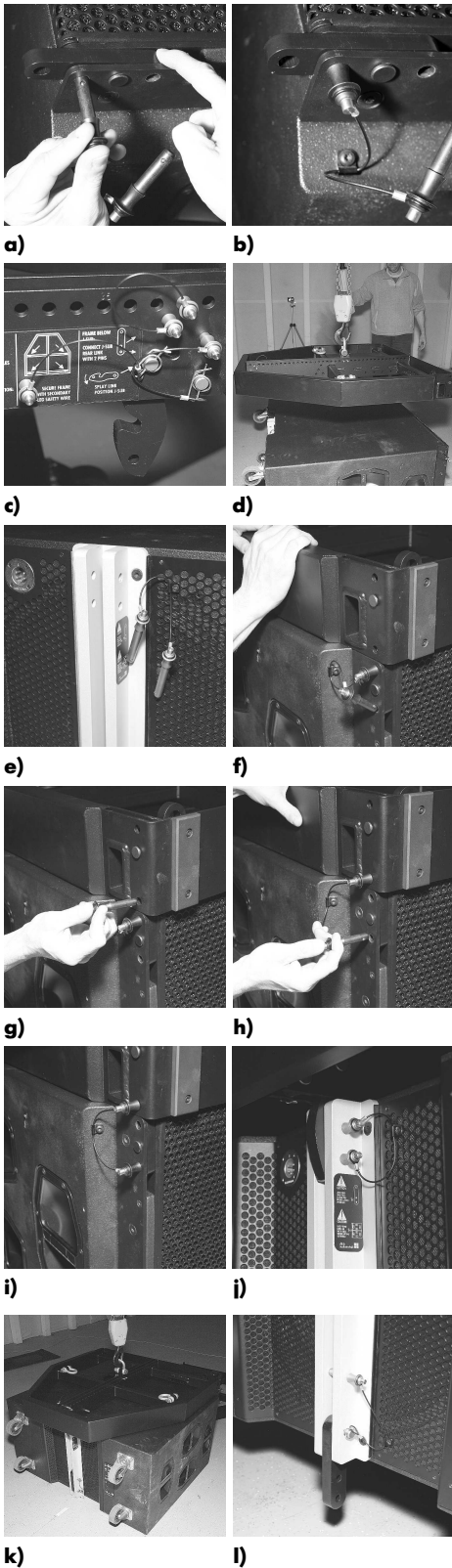

Fig. 33: Preparation and assembly J-SUB

Preparation and assembly of the first J-SUB cabinet (Fig. 33a-k)

7. Remove the transport lid of the J-SUB
8. Release and remove both Locking pins of the cabinet's Front links and slid out to their stop position (Fig. 33a).
9. Insert one pin to the respective socket to fix the Front links in place as shown in Fig. 33b.
10. Lift the Flying frame using the hoist to allow the J-SUB to be positioned below the frame.
11. Fold out the Splay link of the frame (J-SUB position) by releasing the respective Locking pin (Fig. 33c).
12. With one person to each side of the J-SUB tip the cabinet on its bottom panel and position the cabinet below the frame (Fig. 33d).
13. Release and remove both Locking pins at the top of the central rigging strand at the rear of the cabinet (Fig. 33e).
14. Lower and position the frame on the top panel of the cabinet (Fig. 33f).
15. Insert and lock the Locking pins of the cabinet to the respective holes of the Flying frame (Fig. 33g).
16. **IMPORTANT:** Alter the position of the Locking pin at the cabinet as shown in (Fig. 33h/i).
17. Fix the Splay link of the frame at the central rigging strand at the rear of the cabinet using both Locking pins (Fig. 33j).
18. Lift the assembly to a suitable height and fold out the Rear link at the bottom of the central rigging strand at the rear of the J-SUB cabinet.

The assembly is now prepared for the attachment of further J-SUB cabinets or the second Flying frame.

Attaching further J-SUB cabinets

The assembly of further J-SUB cabinets is carried out in the same manner as described above.

19. Lift the assembly to a suitable height to allow the next J-SUB to be positioned below.
20. Prepare the next J-SUB and place the cabinet below the assembly.
21. Lower and position the assembly on the prepared J-SUB cabinet and lock all Locking pins.
22. Repeat this procedure for all further J-SUB cabinets including cabling.

Preparation and assembly of the second Flying frame (Fig. 34a – j)

To allow J8/J12 cabinets to be attached below J-SUB cabinets a second J Flying frame must be used as an adapter.

The J Flying Frame can be picked up by the flown J-SUB column directly from the E7441 Touring case. For this purpose the Flying frame needs to be positioned in the case with the hole grid of the center bar facing upwards and the front of the frame facing towards the wooden baseboard of the case.

Note: The graphics opposite are without the Touring case.

Prepare the second Flying frame as follows:

23. The Splay link of the frame must be fitted in J8/J12 position. Alter the position if necessary as described in section 3.4 Splay link position at the Z5300 J Flying frame on page 12.

24. Remove the additional Front links [1.7] together with the Locking pins from the park position at the frame.

25. Attach the Front links at the top of the front tracks of the frame and fix them with the Locking pins. Observe the direction of attachment - Fig. 34a/b.

26. Release and slide out the cable pick [1.4] by removing the respective Locking pin and refit the Locking pin back to its socket - Fig. 34c.

27. Remove the additional Locking pins [1.5] from the park position at the frame - Fig. 34d. These Locking pins are used to fix the Rear link of the lowest J-SUB cabinet to the frame in a later step.

28. Lower and position the prepared J-SUB assembly on the Flying frame in the Touring case - Fig. 34e/f.

29. Connect the Front links to the lowest J-SUB cabinets using the Locking pins - Fig. 34g/h.

30. Fix the Rear link of the respective J-SUB cabinet to the frame using the additional Locking pins [1.5] - Fig. 34i/j.

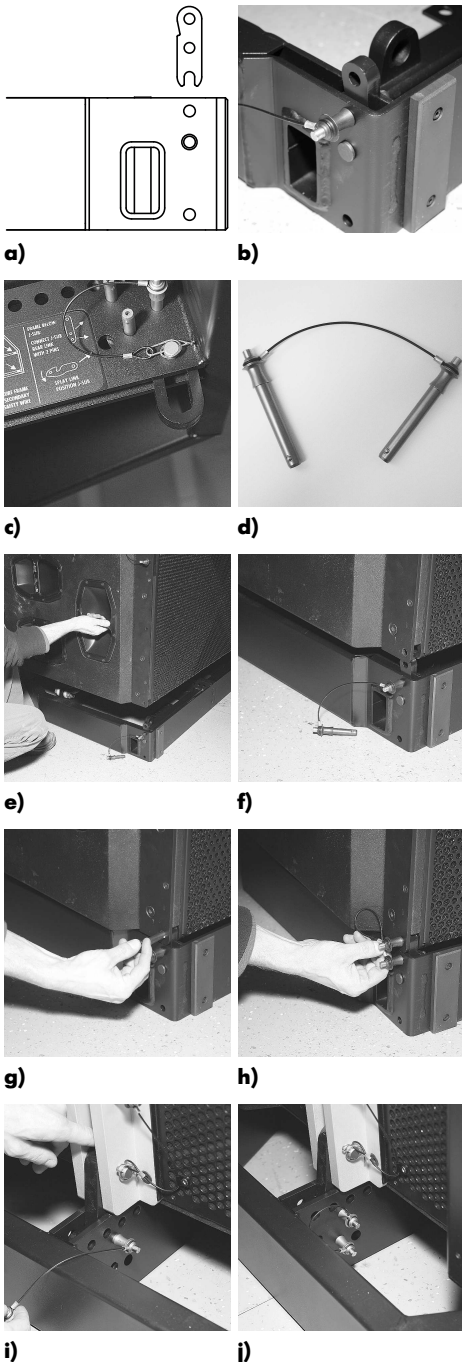
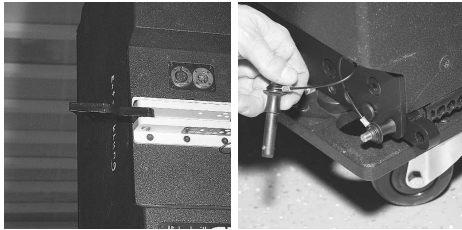

Fig. 34: Preparation and assembly second Flying frame



a)

b)



c)

d)



e)

f)



g)

h)

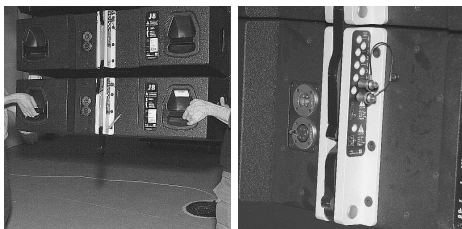

i)

j)

Fig. 35: Preparation and attachment of the J8/J12 cabinets

Attach the J8/J12 cabinets (Fig. 35a-j)

31. Lift the array to a suitable height using the hoists.
32. Fold out the Splay link of the frame (J8/J12 position) - Fig. 35a.
33. Preset the Locking pin at the central rigging strand at the rear of the first cabinet to the 0° position - Fig. 35b.
34. Fold out the Splay link of the first cabinet - Fig. 35c.
35. Prepare the Front links of the cabinet - Fig. 35d.
36. With one person at each side of the cabinet remove the wheel board and lift the cabinet with the front grill facing towards the front. Insert the Front links into the rigging tracks at the front of the frame.
37. Fix the cabinets Front links at the frame with the Locking pins - Fig. 35e.
38. Lift the back of the cabinet until the Splay link of the frame has hooked over the Locking pin at the rear rigging strand of the cabinet.
39. Secure the Splay link with the second Locking pin using the 4° position. - Fig. 35f.
40. Attach all further cabinets in the same manner. Proceed as follows:
 - Preset the desired Splay angle at the respective cabinet (0° ... 6°) at the central rigging strand at the rear of the cabinet by inserting the respective Locking pin. 7° degrees settings are done when the cabinet is being attached to the array – see Fig. 35g – cabinet can swing out to the front.
 - Prepare the Front links as shown in Fig. 35d.
 - Fold out the Splay link. (not necessary for lowest cabinet of the array)
 - Lift the cabinet and insert the Front links into the cabinet above and fix the Locking pins - Fig. 35g.
 - Lift the back of the cabinet until the its Splay has hooked over the Locking pin of the cabinet above - Fig. 35h/i.
 - Secure the Splay link with the second Locking pin using the preset pin - Fig. 35j.

Rig the cabling

41. Connect the flying cables and link cables according to the number of amplifier channels and cabinets used. If the amplifiers are already wired and powered on, using their System check function or channel mute switches and a test signal the correct function and routing of all channels and cabinets can be verified.

Hoisting and securing of the array

When all the mechanical adjustments, system checks and safety checks have been made the array can be hoisted up to its operating position.

When hoisting the array, ensure that the loudspeaker cables do not get caught anywhere. The cables can be strapped together with the motor cable to form a loom while the system is hoisted.

The chain hoist motors must raise the system slowly and evenly so that it does not swing or move from side to side during hoisting.

When the array is in its final operating position the secondary safety must be applied. A detailed description is given in 3.6 Secondary safety on page 15.

4.2.2. Derigging

To lower the array and dismantle it, follow the assembly instructions in reverse order. The same safety instructions apply.

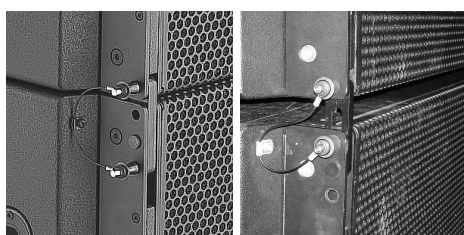

a) b)
Fig. 36: J-SUB Front Link
Setting of the Locking pins for 0° or 2°



WARNING!

4.3. Variant 3: J-SUB Array

The set up of SUB arrays is carried out in the same manner as described in section 4.2 Variant 2: J-SUB and J8/J12 Arrays from page 22 (Steps 1 – 21 - Fig. 33a-k).

If desired J-SUB arrays can also be curved. Depending on the chosen socket for the Locking pins of the J-SUB Front links a splay angle of 0° (Fig. 36a) or 2° (Fig. 36b) can be applied to the front of the cabinet. The splay angle of 2° is achieved by the slot in the J-SUB Front links and will only be effective when the array gets lifted.

4.4. Variant 4: J-Series ground stacks

Ground stacked set ups must always be secured against movement and possible tipping over.

4.4.1. Limitations for J-Series Ground stacks

The following limitations apply:

- A maximum of six J-TOP (J8/J12) cabinets mounted on the J Flying frame.
- A maximum of four J-SUB cabinets and six J-TOP (J8/J12) cabinets mounted on the J Flying frame on top of the J-SUB cabinets.

4.4.2. Preparations

For both applications the Splay link of the frame must be fitted in J-SUB position. Check the position of the Splay link and alter the position if necessary as described in section 3.4 Splay link position at the Z5300 J Flying frame on page 12.

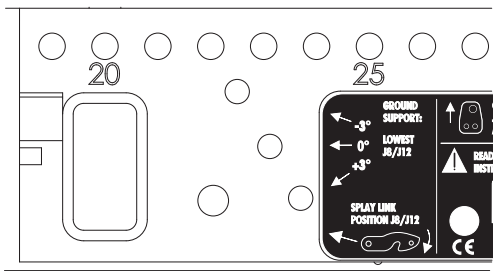

Fig. 37: Hole grid [2.2]

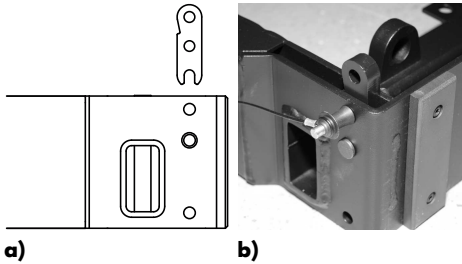
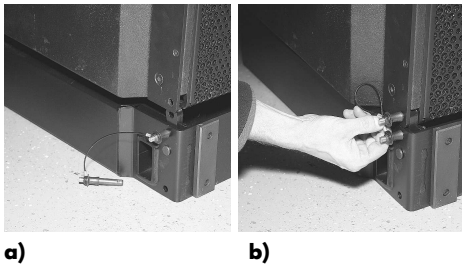

Fig. 38: J8/J12 Ground stack Preparation of the Flying frame



c) Hole grid Ground stack

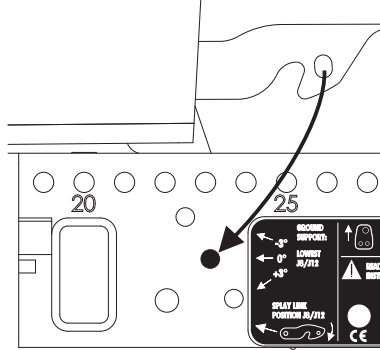
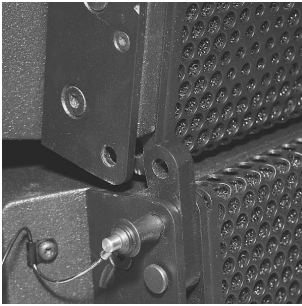

Fig. 39: J8/J12 Ground stack Assembly of the first cabinet at the Flying frame

4.4.3. J8/J12 ground stack assembly

The hole grid [2.2] (Ground stack) at the Flying frame (Fig. 37) allows the first J-TOP cabinet to be set to a fixed vertical aiming of -3° , 0° or $+3^\circ$.

1. Place the Flying frame on the ground with the hole grid of the center bar facing upwards.
2. Remove the additional Front links [1.7] and the respective Locking pins from the park position at the frame.
3. Attach the Front links at the top of the front tracks of the frame and fix them with the Locking pins. Observe the direction of attachment - Fig. 38a/b.
4. Remove the additional Locking pins [1.5] from the park position at the frame. These Locking pins will be used in a later step to fix the Splay link of the lowest J-TOP cabinet to the frame.
5. With one person at each side of it attach the first cabinet to the Flying frame inserting the additional Front links of the frame into the rigging tracks at the front of the cabinet and connecting them using the second Locking pins - Fig. 39a/b.
6. Remove the wheel board.
7. Fold out and insert the Splay link of the cabinet into the track of the center bar of the frame and fix it to the frame using one of the additional Locking pins. In this case the hole (drill) of the cabinet's Splay link is used. It supports the cabinet and defines the angle setting in the hole grid of the frame (-3° , 0° or $+3^\circ$) - Fig. 39c.
8. The second pin is not needed and should be stored in a hole of the center grid of the frame.
9. Prepare the Front links of the cabinet to allow the next cabinet to be attached.
10. Preset the splay angle ($0^\circ \dots 6^\circ$) to the cabinet above at the rear rigging strand by inserting one Locking pin to the respective hole.



a)

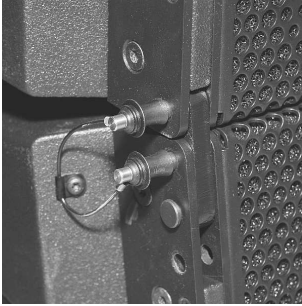

b)

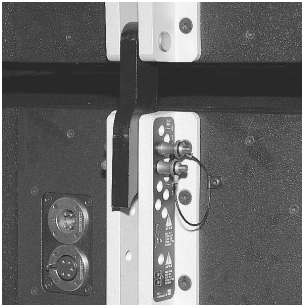

c)

Fig. 40: Attaching the J8/J12 cabinets

11. Remove the wheel board of the next cabinet.

12. Add the next cabinet. With one person to each side of the cabinet insert the Front links to the rigging tracks at the front of the cabinet - Fig. 40a.

13. Fix the cabinets Front links with the second Locking pins - Fig. 40b.

14. Fold out the Splay link of the cabinet and connect it to the cabinet below as follows:

- Lower the back of the cabinet until the Splay link has hooked over the preset Locking pin.
- Raise the back of the cabinet until the Splay link has completely hooked into the Locking pin.
- Insert the second Locking pin to fix the desired splay angle.

15. Attach all cabinets in the same manner until the assembly is completed.

Wiring

16. Connect the cables and link cables according to the number of amplifier channels and cabinets used.

Securing the set up

Secure the ground stack against movement and possible tipping over.

Derigging

To dismantle the ground stack, follow the assembly instructions in reverse order. The same safety instructions apply.

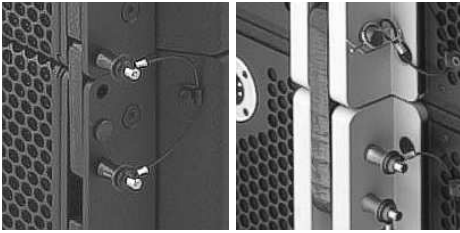

a) b)

Fig. 41: Interconnection of the J-SUBs



a)



b)

Fig. 42: J-SUB and J8/J12 Ground stack Assembly of the Flying frame



a) b)

Fig. 43: Interconnection of the J-SUBs

4.4.4. Ground stack with J-SUB and J8/J12

Setting up a ground stack consisting of J-SUB and J8/J12 cabinets first the subwoofer cabinets are stacked on the floor and connected together with their Front and Rear links - Fig. 41. The J Flying frame is placed on top of them to support the J8/J12 cabinets

Set up

1. Remove the transport lid of the J-SUB cabinet.
2. With one person at each side of the J-SUB tip the cabinet on its bottom panel.
3. For additional J-SUB cabinets proceed in the manner as described in step 1 and 2 and position the cabinets on top of each other.
4. Interconnect the cabinets with the Front and Rear links of the cabinets - Fig. 41.

Attaching the Flying frame

5. Position the Flying frame on top of the uppermost J-SUB cabinet with the hole grid of the center bar facing upwards.
6. Fix the Flying frame to the top J-SUB cabinet with the Front links of the cabinet and the Splay link of the frame (J-SUB position).

Attaching the J8/J12 cabinets

7. The assembly of the J8/J12 cabinets on top of the J-SUB cabinets is carried out in the same manner as described in section 4.4.3 J8/J12 ground stack assembly on page 27.

Wiring

8. Connect the cables and link cables according to the number of amplifier channels and cabinets used.

Securing the set up

9. Secure the ground stack against movement and possible tipping over.

Derigging

To dismantle the ground stack, follow the assembly instructions in reverse order. The same safety instructions apply.

4.4.5. J-SUB stacks

Conventional J-SUB stacks are set up in the same manner as described in the previous section. For conventional ground stacks of J-SUB cabinets we also recommend to interconnect the cabinets with their Front and Rear links - Fig. 43.

Secure the stack against movement and possible tipping over.

5. Wind loads

When loudspeaker arrays are flown in an open air environment, possible wind effects should be taken into account. Wind load will produce additional dynamic forces to the rigging components and the suspension, which may lead to a dangerous situation.



WARNING!

Generally flying loudspeakers overhead at wind forces higher than 6 bft is not recommended.

When planning an open air event it is essential to get current weather and wind information.

The following wind speed scale according to Beaufort gives an impression of the effects of the different wind forces (bft).

bft	knots	km/h	mph	Description	Effects on land
0	0-1	0-1	0-1	Calm	Smoke rises vertically.
1	1-3	1-5	1-3	Light Air	Direction of wind shown by smoke drift, but not by wind vanes.
2	4-6	6-11	4-7	Light breeze	Wind felt on face; leaves rustle; ordinary vanes moved by wind.
3	7-10	12-19	8-12	Gentle breeze	Leaves and small twigs in constant motion; wind extends light flag.
4	11-16	20-28	13-18	Moderate breeze	Raises dust and loose paper; small branches are moved.
5	17-21	29-38	19-24	Fresh breeze	Small trees in leaf begin to sway; crested wavelets form on inland waters.
6	22-27	39-49	25-31	Strong breeze	Large branches in motion; whistling heard in telegraph wires; umbrellas used with difficulty.
7	28-33	50-61	32-38	Near gale	Whole trees in motion; inconvenience felt when walking against the wind.
8	34-40	62-74	39-46	Gale	Breaks twigs off trees; generally impedes progress.
9	41-47	75-88	47-54	Severe gale	Slight structural damage occurs (chimney-pots and slates removed).
10	48-55	89-102	55-63	Storm	Trees uprooted; considerable structural damage occurs.
11	56-63	102-117	64-72	Violent storm	Accompanied by wide-spread damage.
12	> 64	> 117,0	> 72	Hurricane	Heaviest damage and destruction.

Tab. 1: Wind force and its effects on land



WARNING!

If according to the forecast wind forces higher than 5 bft are possible the following actions have to be taken:

- **The actual on site wind speed has to be monitored permanently. Be aware that wind speed typically increases with height above ground.**
- **Suspension and securing points of the array should be designed to accommodate double the static load in order to withstand any additional dynamic forces.**

If the wind force exceeds 8 bft there is a risk of mechanical damage to the components which may lead to a dangerous situation for persons in the vicinity of the flown array.

Stop the event and make sure that no one is left within the vicinity of the array.

Lower down and secure the array.



WARNING!

6. Care and maintenance / Disposal

6.1. Transport / Storing

During transport ensure the rigging components are not stressed or damaged by mechanical forces. Use suitable transport cases.

Due to their surface treatment the J-Series rigging components are temporarily protected against moisture. However, ensure the components are in a dry state while stored or during transport and use.

6.2. Visual and functional inspection

Cabinet enclosure:

- Visual inspection of all fitting plates for obvious damage (e.g. cracks or corrosion).
- Inspection of all fitting plates including front grills to ensure they are securely attached.
- Regularly lubricate the sockets with WD-40® or a similar product.

Locking pins

- Visual inspection regarding deformation and corrosion of the component.
- Inspection for missing ball bearings and damage.
- Functional inspection of the release mechanism to check it functions properly.
- Regularly lubricate Locking pins with WD-40® or a similar product.

Front and Splay (Rear) links

Visual inspection regarding deformation and damage (e.g. cracks and corrosion) including all drilled holes of the component.

Z5300 J Flying frame

- Visual inspection regarding deformation and damage (e.g. cracks and corrosion) including all drilled holes of the component.
- Regularly check the flatness of the Flying frame. For this purpose position the Flying frame on a flat surface and visually check the frame for deformation and/or torsion. For obvious deformation and/or torsion contact d&b audiotechnik for further advice and how to proceed.

Z5303 J Safety chain

Z5305 J Hoist connector chain

Inspection according to the appropriate regulations for lifting devices (EN 818-6:2000 Regularly inspection within a 12 month period. Regularly inspection for cracks within a 36 month period).

6.3. Disposal

When out of use the rigging components must be disposed in accordance to the national environmental regulations.

Ensure that damaged rigging components are disposed in a way that they can not be used again.

EC Declaration of Conformity

within the meaning of the EC Machine Directive 98/37/EEC

We hereby declare that the equipment designated below is designed and built in the version sold by us in such a way as to comply with the relevant fundamental safety and health criteria of the applicable EC Directive(s). This declaration shall cease to be valid if alterations are made to the equipment without our prior agreement.

This declarations covers:

- **d&b Z5300, J Flying frame including:**
 - **d&b J Load adapter**
 - **d&b J Front link Frame**
 - **d&b J Splay link Frame**
 - **d&b J Locking pins**
 - **d&b Z5303 J Safety chain set**
- **d&b Z5305 J Hoist connector chain**
- **d&b J-Series loudspeaker cabinets** (with integrated rigging components):
 - **d&b Z0650, J8 loudspeaker**
 - **d&b Z0651, J12 loudspeaker**
 - **d&b Z0660, J-SUB loudspeaker**

Relevant EC Directives:

EC Machine Directive 98/37/EC

National standards and technical specifications applied, in particular:

DIN EN ISO 12 100, DIN EN 1050, BGV C1

Backnang 2007-02-16

(Frank Bothe, Director)

d&b
audiotechnik 

